

INESC PORTO
LABORATÓRIO ASSOCIADO



E-Mobility and the Smart Grids - The MERGE project -

J.A. Peças Lopes

ISGT 2010, October 11-13, 2010, Lindholmen Science Park, Gothenburg, Sweden



MERGE Partners

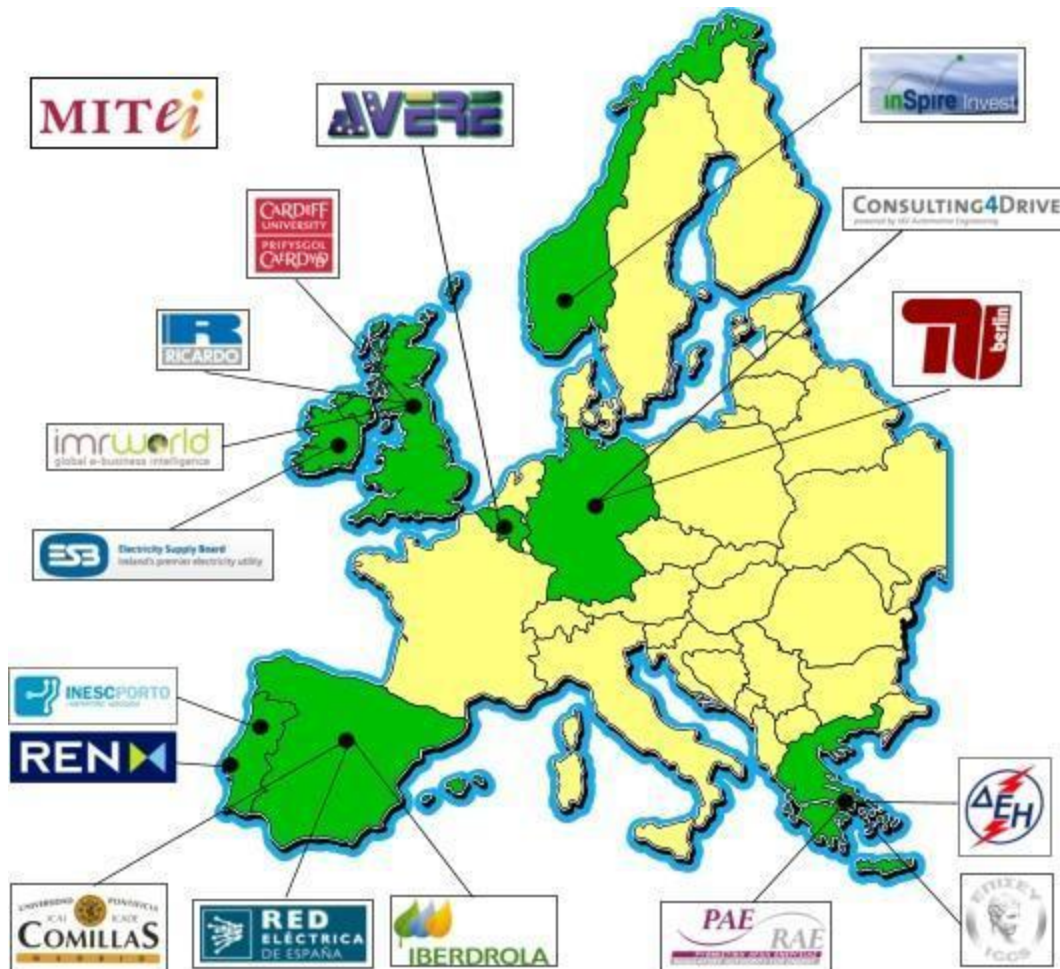



Main Conceptual Approach in the MERGE Project

- Development of a methodology with two synergetic pathways:
 - Development of a management and control concept that will facilitate the actual transition from conventional to electric vehicles - the MERGE concept;
 - Development of an evaluation suite of tools based on methods and programs enhanced to model, analyze, and optimize electric networks where EV and their charging infrastructures.
 - Analysis of the Impacts of the presence of EV on EU grids for 2020 and 2030.



How to Address E_mobility problems

- Need to understand the behavior of EV drivers → Inquiries
- Impacts in Power System operation
- Definition of management solutions with implications on battery charging modes
- Design of charging infrastructures



RESULTS FROM THE MERGE PROJECT: REFUELLING AND RECHARGING REGULARITY/TIMING PREFERENCES

When do you / would you choose to refuel your vehicle?

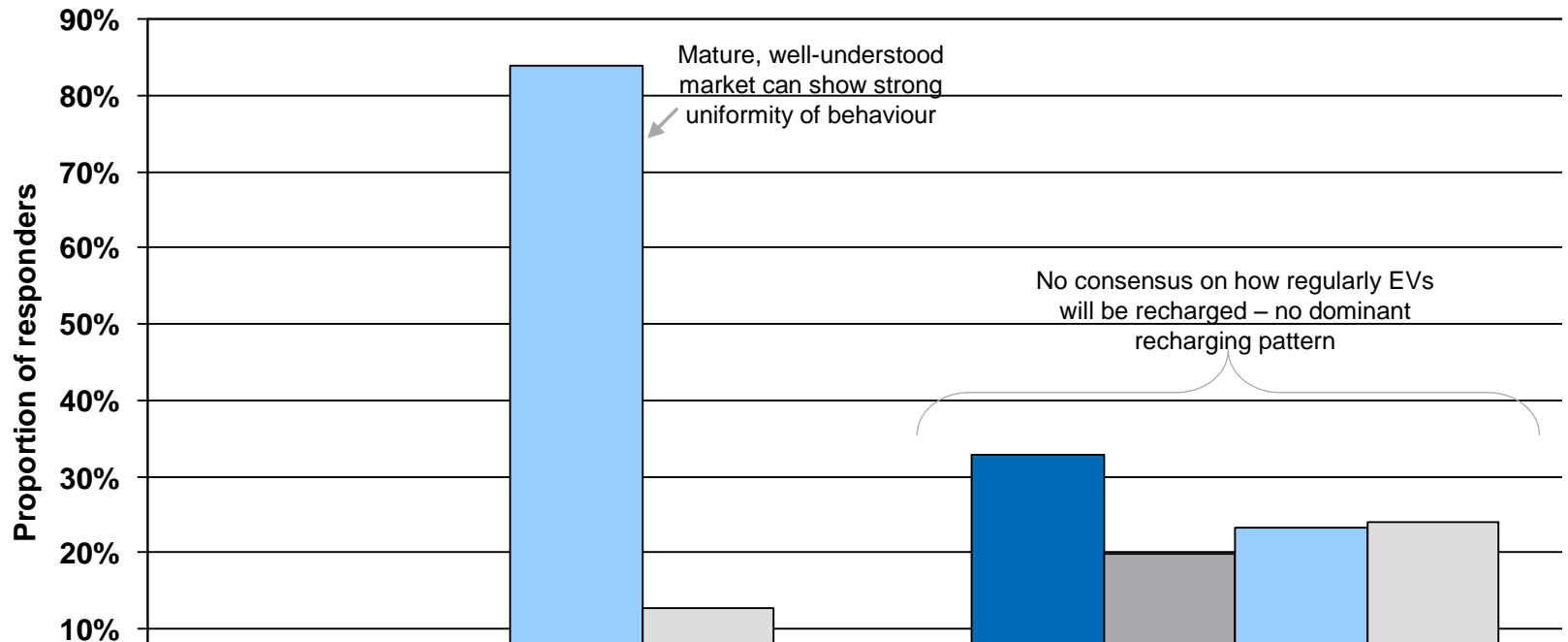



RESULTS FROM THE MERGE PROJECT: REFUELLING AND RECHARGING LOCATION PREFERENCES

Where do you / would you choose to refuel your vehicle?

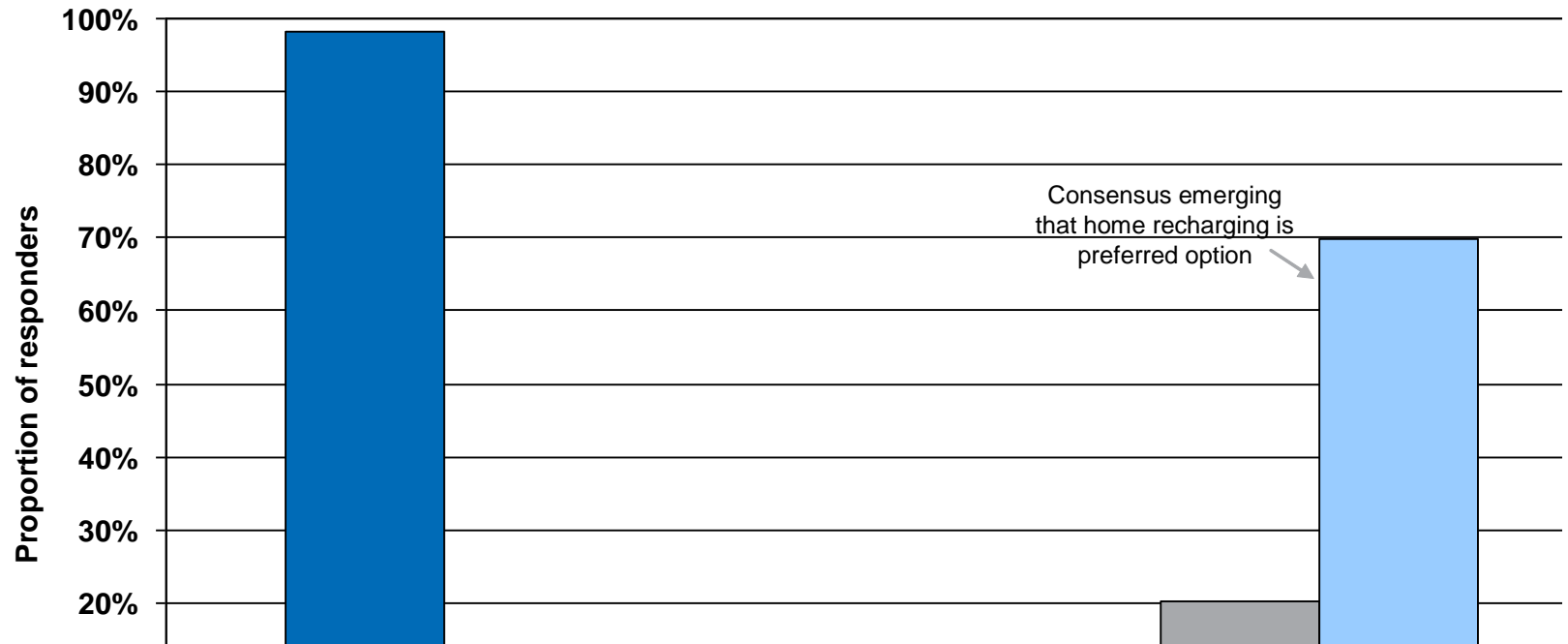



RESULTS FROM THE MERGE PROJECT: VARIATION OF DISTANCES, IN KM, TRAVELLED PER DAY ON WEEKDAYS, BY COUNTRY

Proportion of vehicles travelling up to this distance
per day

Distances travelled per day on weekdays

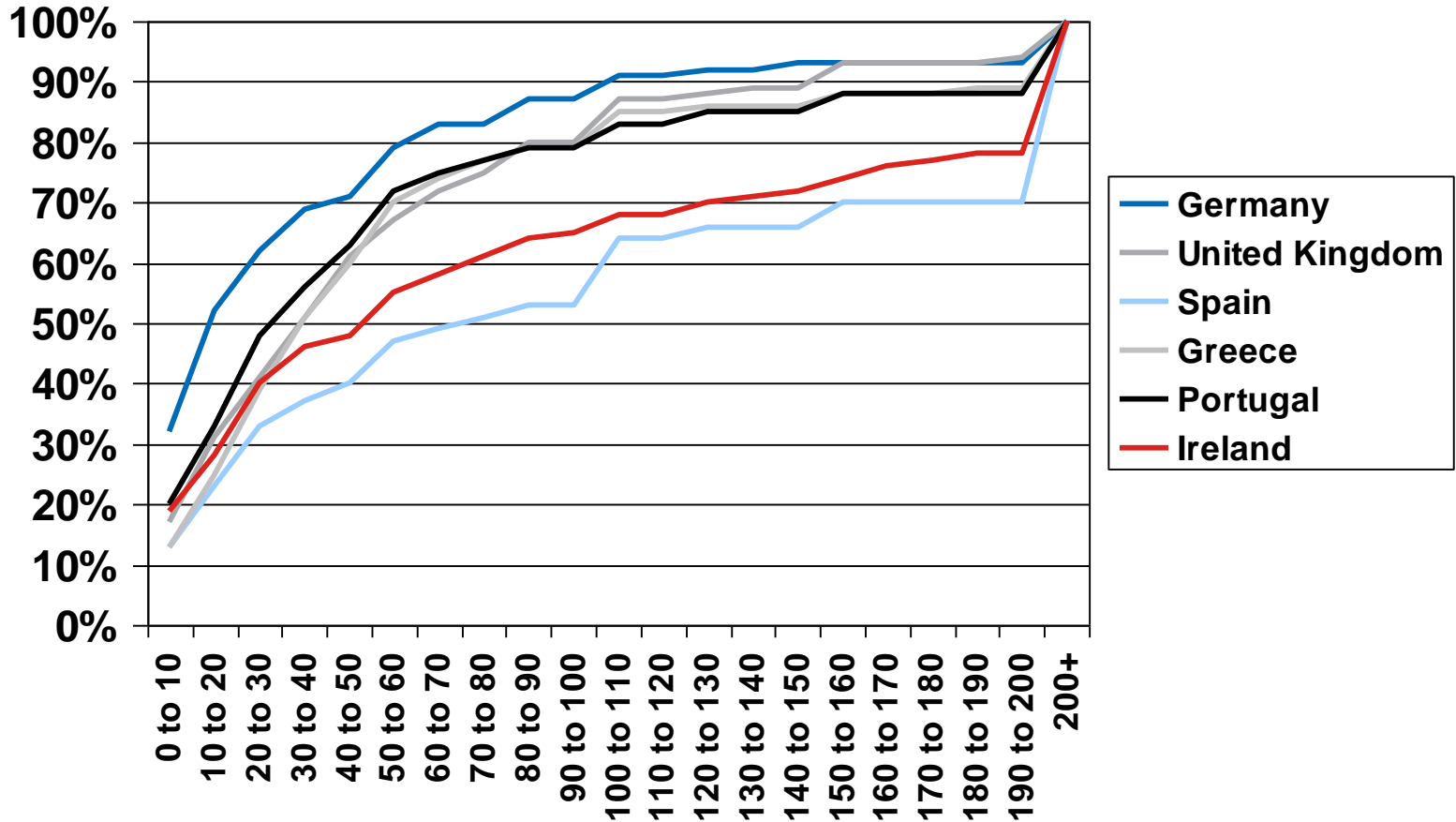



RESULTS FROM THE MERGE PROJECT: PROFILE OF TIME OF RETURN FROM LAST JOURNEY OF THE DAY, PORTUGAL

What time do you return from your last journey of the day?

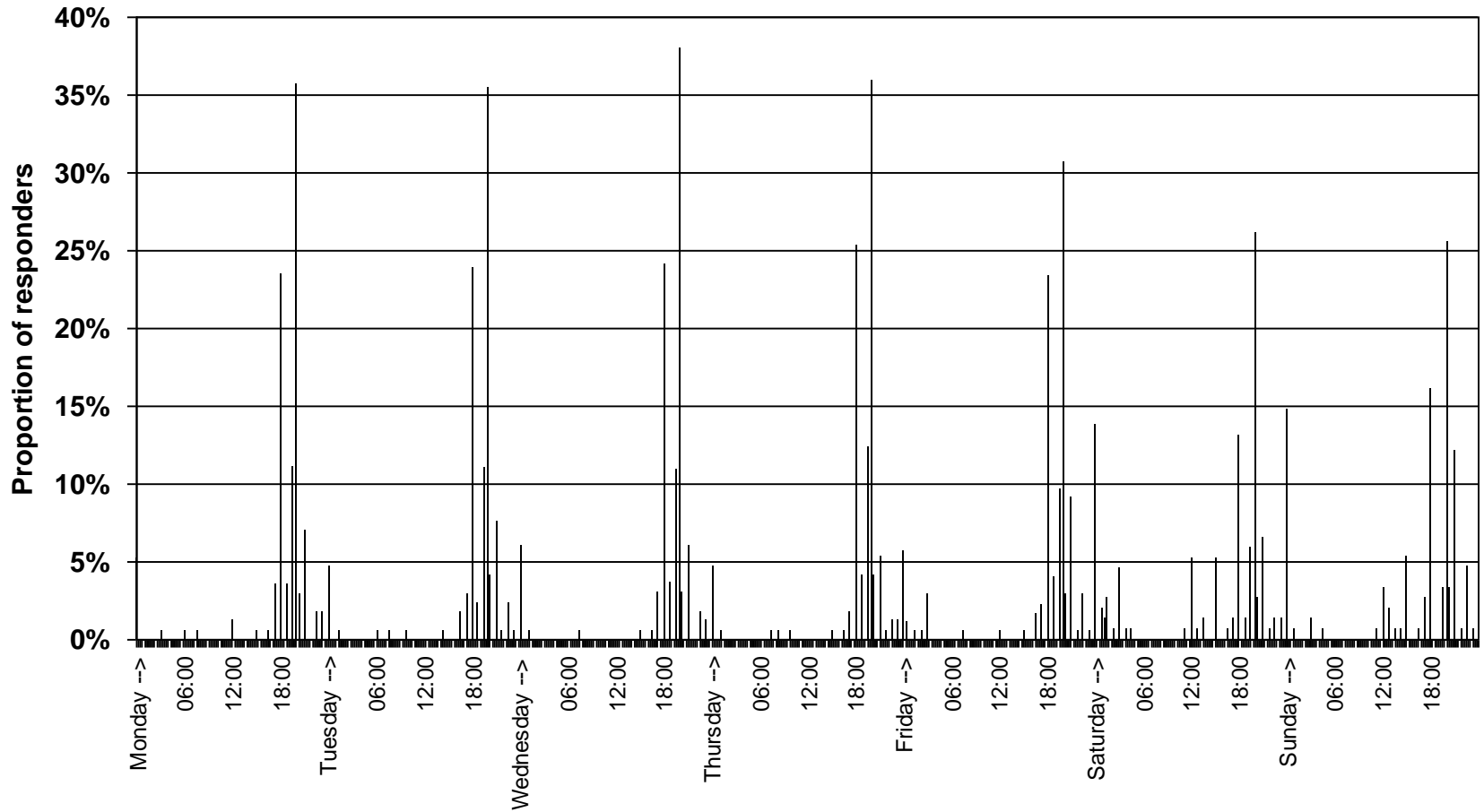



EFFECT OF DUMB CHARGING SCENARIO ON PORTUGAL'S ELECTRICITY DEMAND (10% EV)

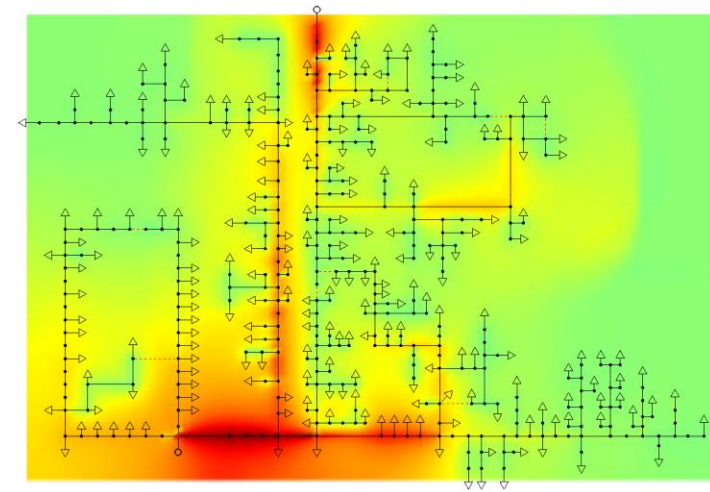
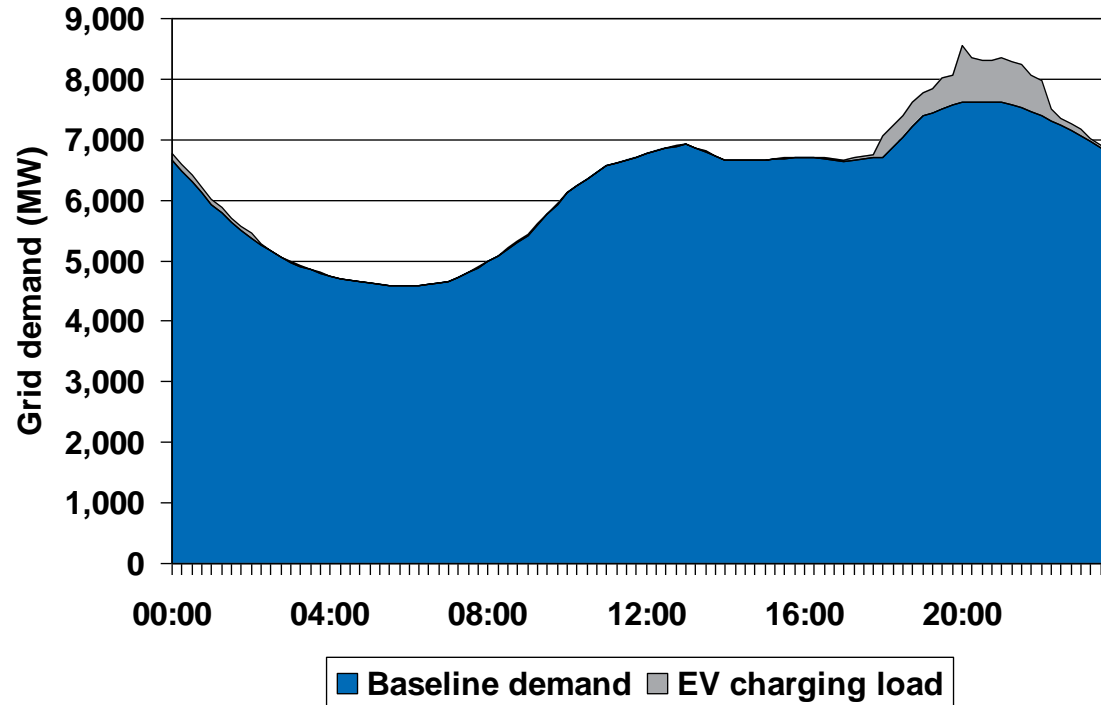

SMART CHARGING IS REQUIRED



CONCLUSIONS

- Developing the Smart Charging concept → moving charging to valey hours (night periods)

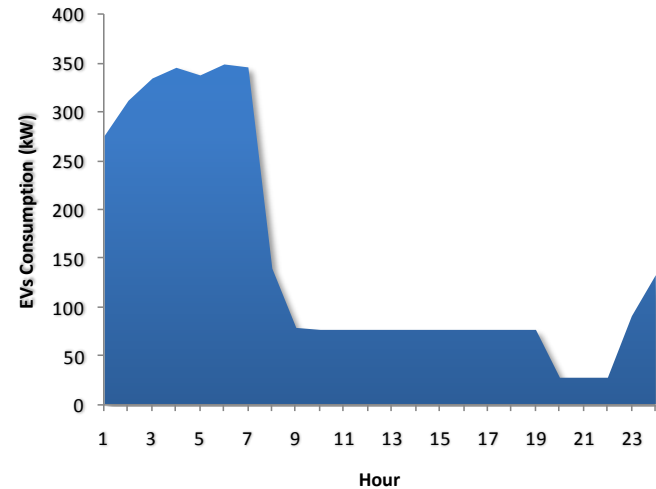
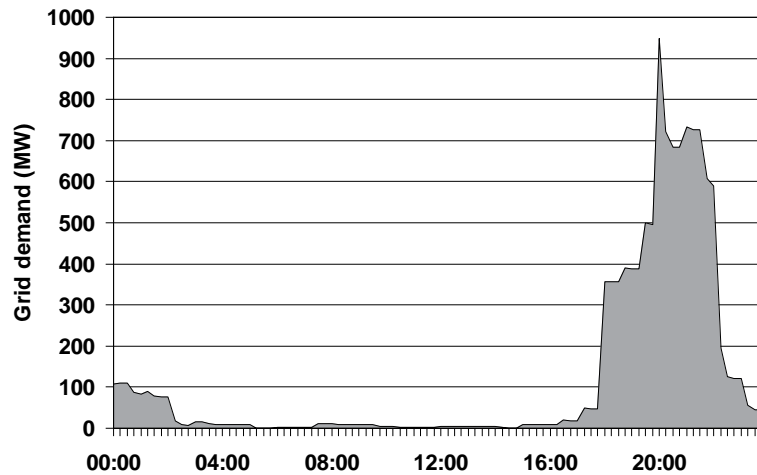



- **A two level hierarchical control approach needs to be adopted:**
 - Local control housed at the EV grid interface, responding locally to grid frequency changes and voltage drops;
 - Upper control level designed to deal with:
 - “short-term programmed” charging to deal with branch congestion, voltage drops
 - Delivery of reserves (secondary frequency control);
 - Adjustments in charging according to the availability of power resources (renewable sources).



RESULTS FROM THE MERGE PROJECT: Conceptual Framework for EV Integration Into Electric Power Systems - *Type of charging points*

Charging points can present different characteristics according to the location

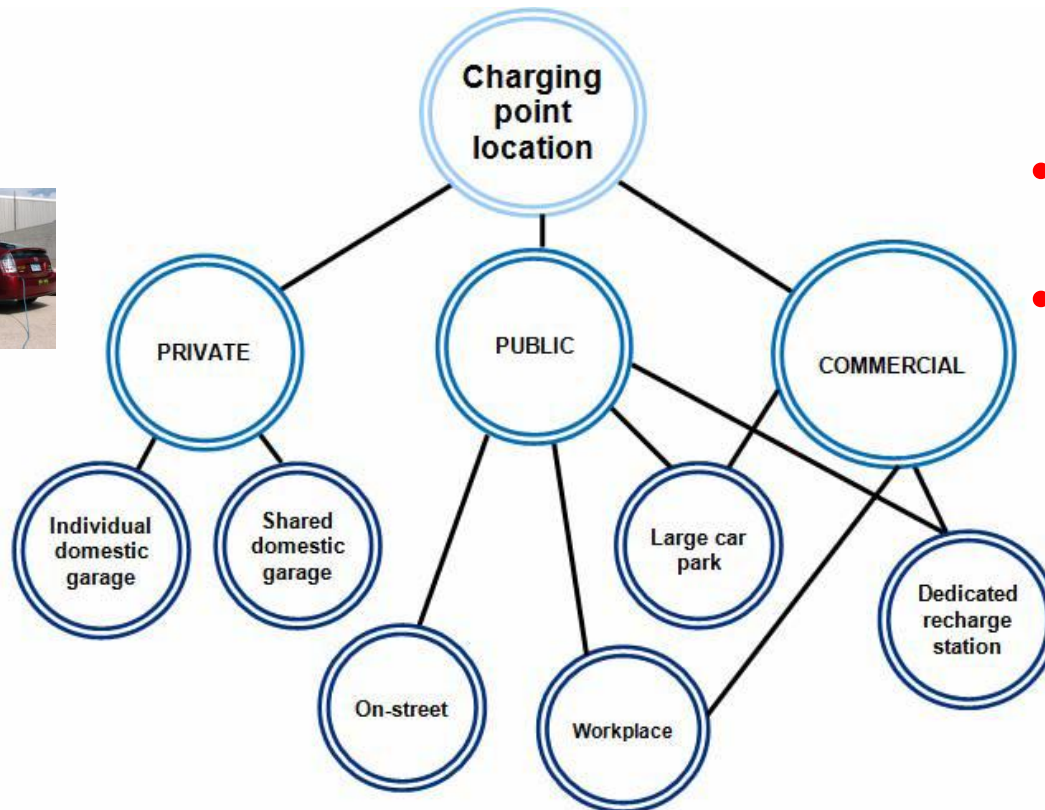

- Dumb charging
- Controlled charging



Fast Charging



RESULTS FROM THE MERGE PROJECT: Conceptual Framework for EV Integration Into Electric Power Systems

Overview of the different information flows

An ICT model was developed, identifying the involved parties and the associated information flows.

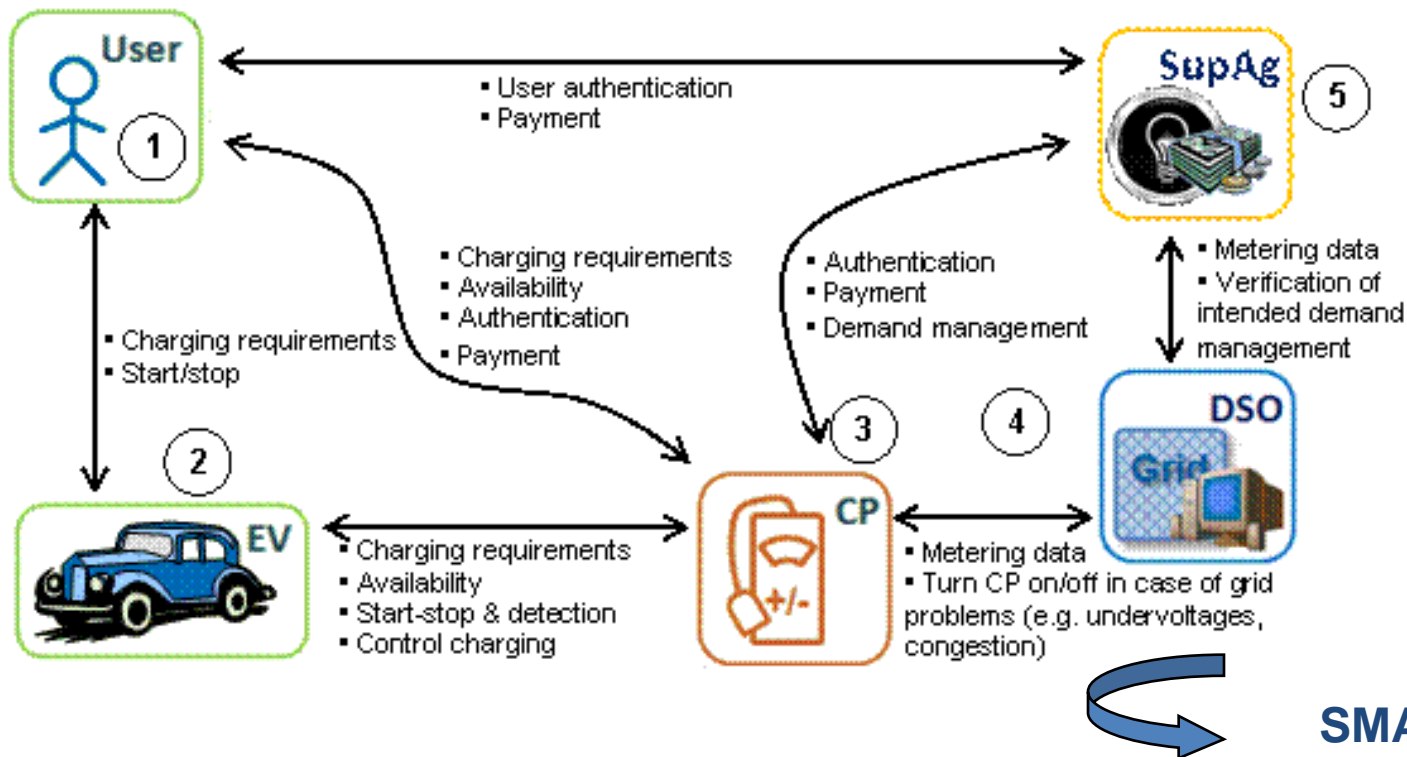



Conceptual Framework For EV Integration

- EV must be an active element within the power system
- The Upper Level control requires interactions with:
 - **An Aggregating** entity to allow:
 - Reserve management
 - Market negotiation

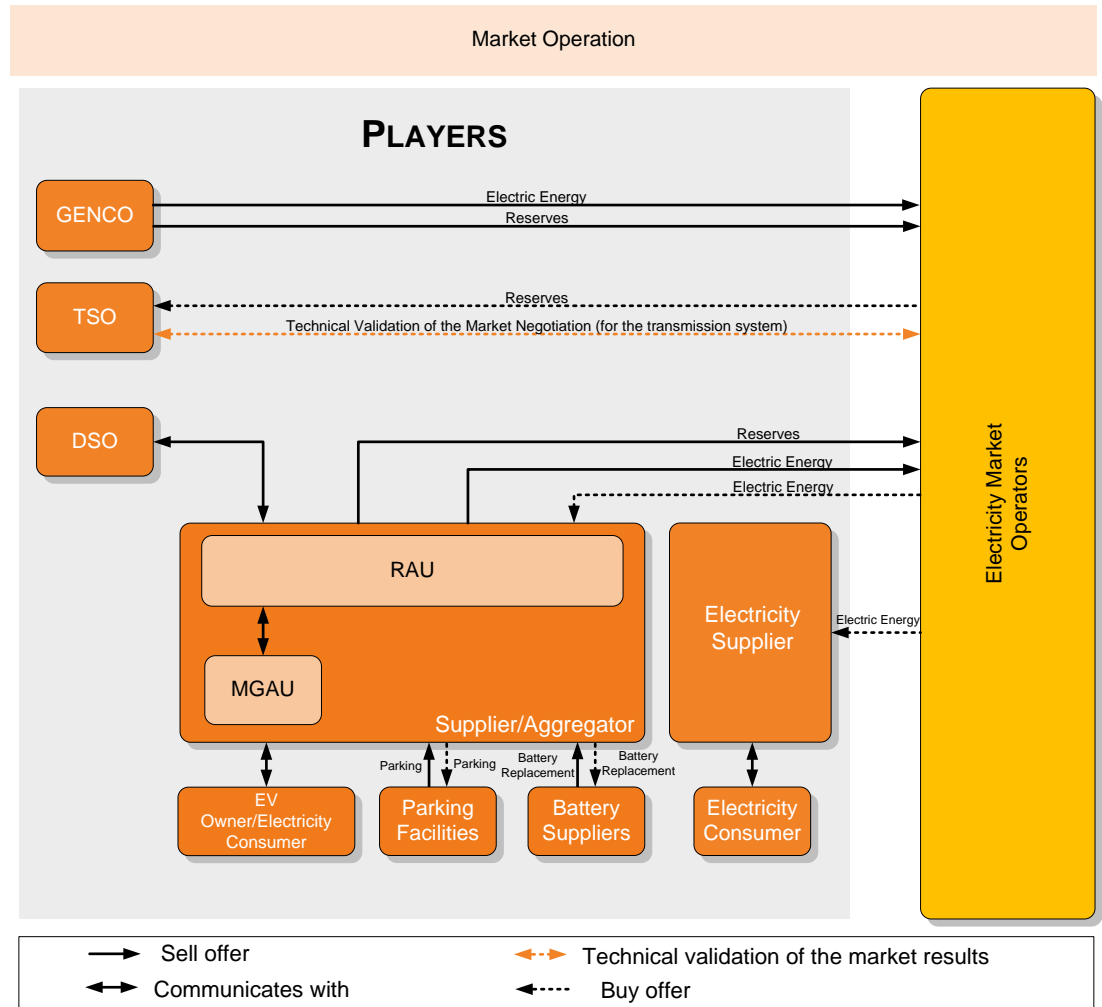



EV Voltage / Frequency support modes

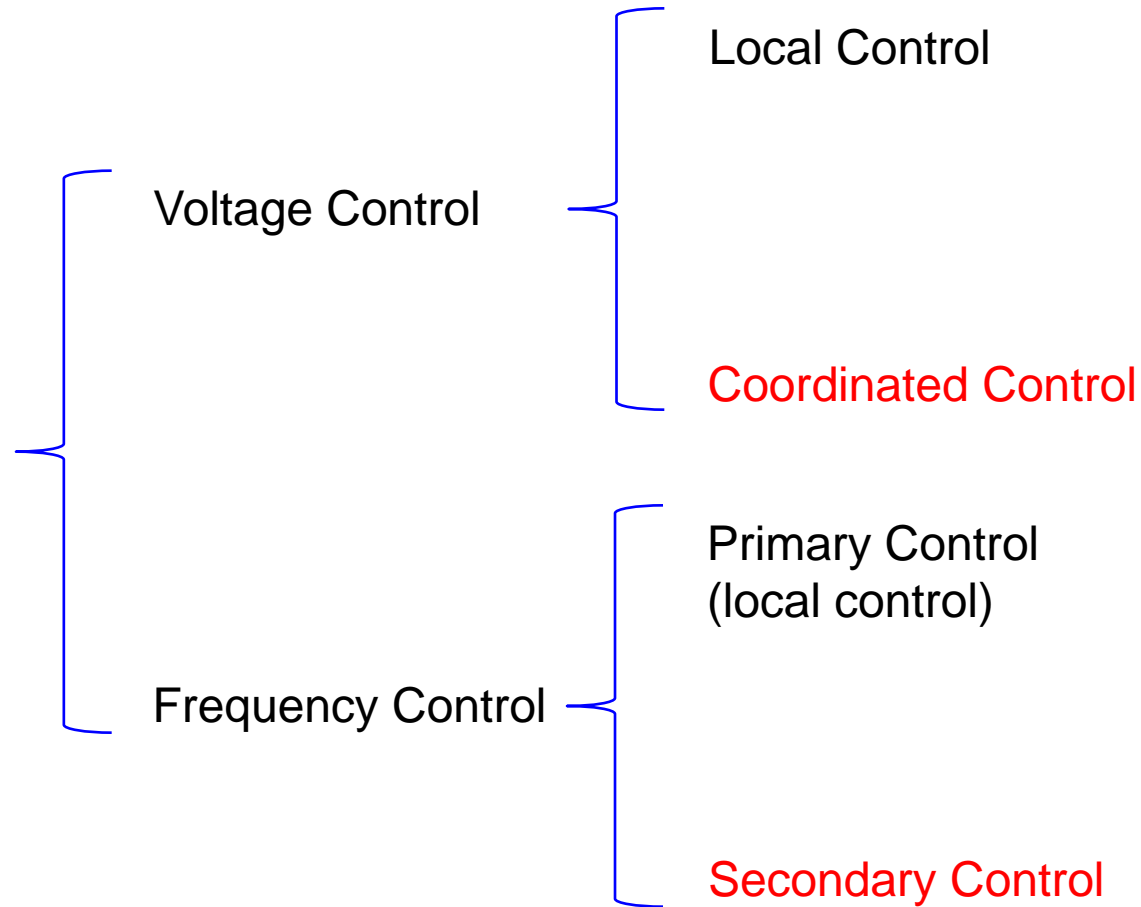



Primary Reserve

EV Electronic Grid Interface Modelling

- For frequency control the envisioned response from EVs is shown in the figure:
 - When facing frequency deviations EVs may slow down/speed up their charging or even inject active power into the grid
 - A dead band for battery premature exhaustion prevention is required
 - P_{rated} MW/Hz proportional gain controls the reaction to frequency deviations

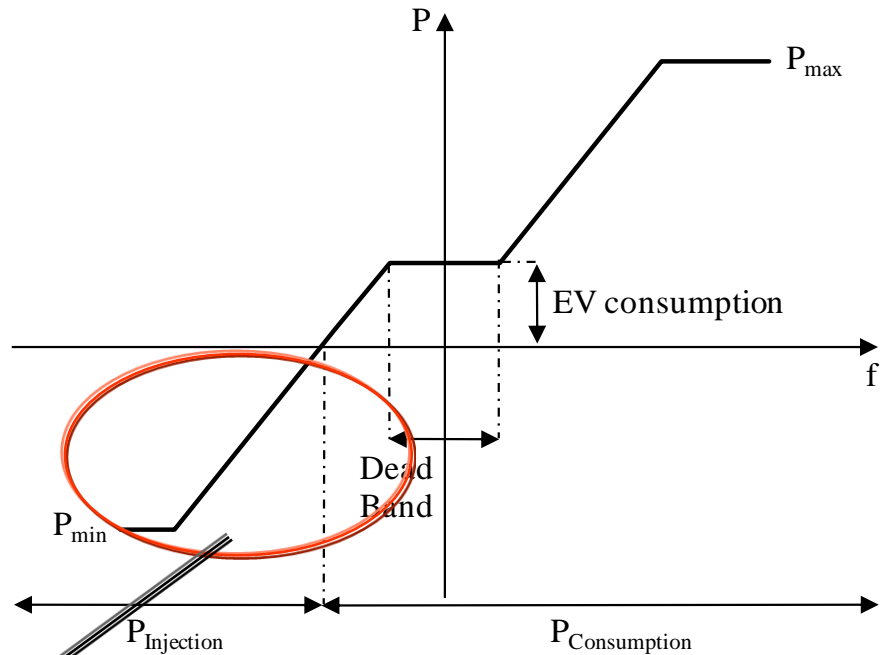

Droop control for EVs

V2G mode



Secondary Reserve - AGC operation with EV

- Modification of the active power set-points of generators and EV
- Some modifications need to be introduced in conventional AGC systems:
 - redefinition of the participation factors and
 - introduction of an additional block to communicate with EV aggregators
- These control functionalities to be provided by EV are intended to keep the scheduled system frequency and established interchange with other areas within predefined limits, enabling further deployment of IRES

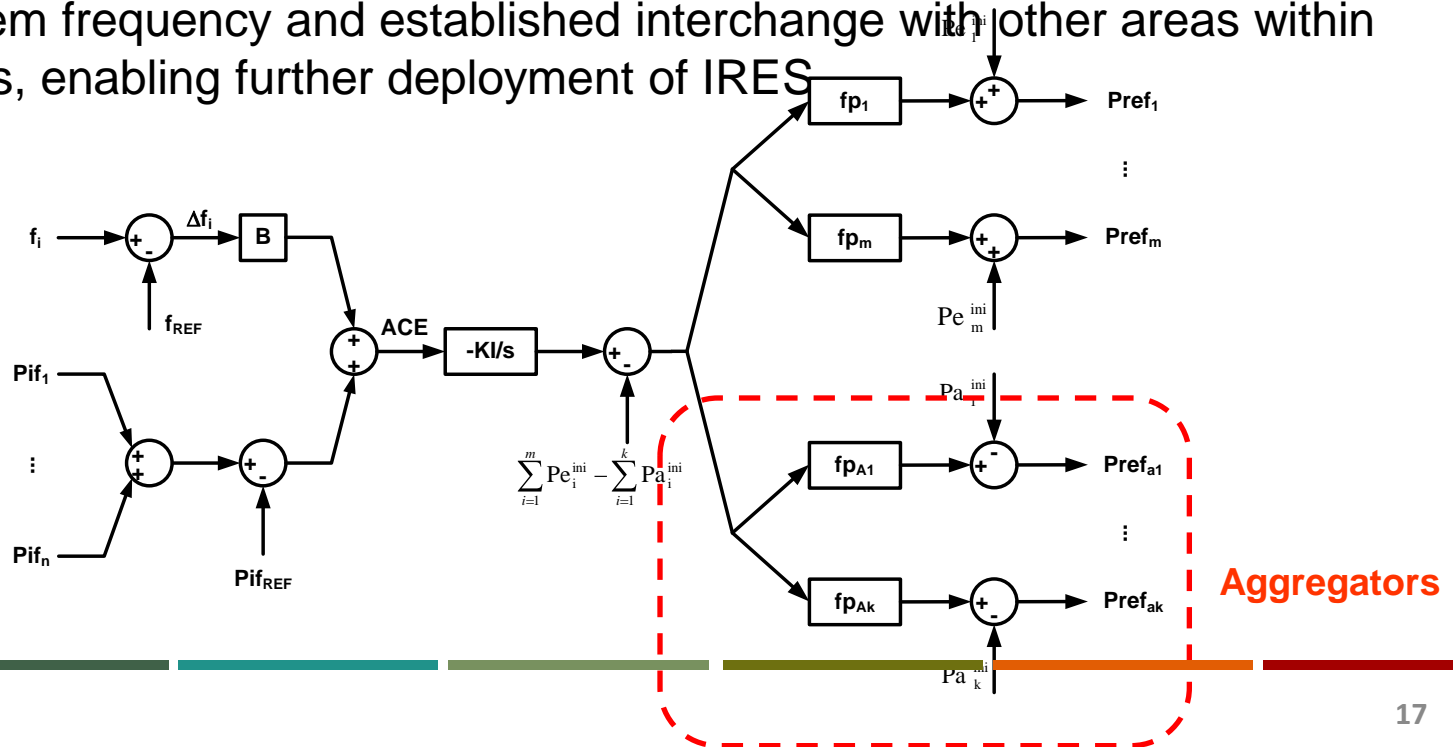



CONCLUSIONS

- **Electric Vehicles will play an important role in the development of the Smart Grid concepts since they are:**
 - High flexible load device
 - Mobile storage device
- The presence of Electric Vehicles, if properly managed, can:
 - provide several ancillary services;
 - allow a larger integration of renewable power sources;
 - increase system robustness of operation.
- If **Smart Charging** and other **Distributed Intelligent solutions** are adopted, the need to reinforce the existing electrical grid and generation infrastructures can be postponed.

<http://www.ev-merge.eu/>